

The Neutralisers

Model #5.521 and Model #5.621

Motivation

In the DMA the particles are selected according to their electrical mobility. This mobility depends on the mechanical mobility of the particle and its electrical charging. To calculate the percentage of selected particles of a certain size range, it is essential to know the charge distribution of the whole aerosol. To be sure that the aerosol is in a stable state of charging, the so-called Nt-product must have at least a quantity of about 10^7 . Where N is the number of ions per cm^3 and t the residence time in seconds of the particles in the ionized atmosphere.

Solution

In the GRIMM neutralisers a radioactive source is used. It is a so-called bipolar charger, because it produces both, negative and positive ions in the atmosphere. The radioactive source is installed in a stainless steel housing, which is totally shielding the radiation. Normally an Am-241 source (#5.522/5.622) is used. The charging of the particles is caused by ionization of the air molecules. Americium is a solid material. The source is covered by a very thin gold foil. Am-241 is an alpha emitter with an energy of 5.6 MeV. About 34 eV are needed to generate one ion pair, so Am-241 is a very efficient neutraliser.

GRIMM offers two different neutraliser housings with sources of different activity for different airflows.

Advances

Some other neutralisers are using Kr-85 as source, which causes some disadvantages, compared to Am-241.

Kr-85	Am-241
Gas with the problem of diffusion loss	solid material, covered with a gold foil
a half-life of 10 years	a half-life of 433 years
beta emitter	alpha emitter with higher ionisation efficiency
β -energy of 0.695 MeV	α -energy of 5.6 MeV
a much higher activity is needed	the needed activity is not very high
β -radiation causes x-ray	there is no x-ray

In the EU: similar handling regulations for all nuclides

Solution

Model #5522: Am-241 source (#5.522) in a stainless steel housing (#5.521) with an activity of 3.7 Mbq for airflows up to 5 lpm
 Model #5622: Am-241 source (#5.622) in a stainless steel housing (#5.621) with an activity of 18.5 Mbq for airflows up to 20 lpm

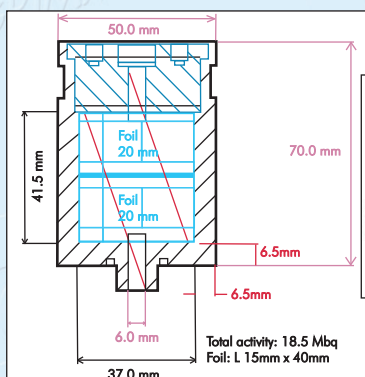

The stainless steel housing (#5.621)

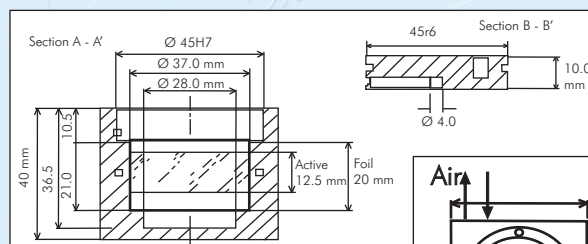

The stainless steel housing (#5.521)

