

Comparison of two Condensation Particle Counters for automotive applications using a combustion soot generator

Jürgen Spielvogel (2), Stefan Carli (1), Sebastian Usarek (1), Lena Brandt, (1), Lothar Keck (2), Markus Pesch (2), Hans Grimm (2), Rene Albrecht (2), Matthias Richter (2)

(1) Volkswagen AG, D-38436 Wolfsburg, (2) GRIMM Aerosol Technik GmbH & Co. KG

The Euro V regulations establish limits for the particle number concentrations in engine exhaust gas. The measurements of these particle number concentrations must be done by a standardized procedure, which specifies the dilution of the exhaust gas, the removal of the volatile aerosol fraction, and the use of a special Condensation Particle Counter (CPC) for the detection of particles. The standardization of the measurements is a work in progress in the frame of the „Particle Measurement Program“ (PMP) of the UN-ECE GRPE. The requirements for such a PMP-CPC are mainly: (1) It must be a full flow CPC, (2) the accuracy against a traceable standard must be better 10%, (3) the CPC must have a linear response ($R^2 > 0.97$), (4) the T90 response time must be less than 5 s, and (5) the counting efficiency must be of 50 +/- 12% for a particle diameter of 23 nm and > 90% for a particle diameter of 41 nm.

We have tested two commercial PMP-CPCs, namely the GRIMM model 5430 and the TSI model 3790, with the setup shown in Fig. 1. Since the characteristics of the soot particles are very similar to those emitted by combustion engines, a Combustion Aerosol Standard (CAST) soot generator (Jing Mini-CAST) was used for the generation of particles. A Vienna-type Differential Mobility Analyzer (GRIMM M-DMA) with a ^{241}Am Neutralizer was used to classify the particles. As a primary standard for particle number concentrations we have used a GRIMM Faraday Cup Electrometer (FCE), a GRIMM standard CPC with a minimum detectable particle size of 4.5 nm was used as additional reference and to monitor the contribution of multiple charged particles. Both FCE and reference CPC were operated with a temperature stabilized critical nozzle to maintain the flow rate with a high accuracy.

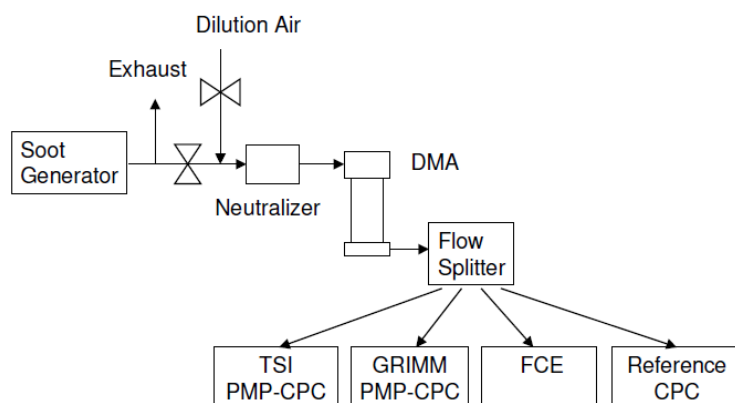

Fig. 1: Experimental setup for the comparison of the two PMP-CPCs.

Accuracy and linearity of the CPCs were determined with eight concentration steps including zero concentration for a particle size of 50 nm. The results, displayed in Fig. 2, indicate that the two tested PMP-CPCs are well within the specifications of the PMP regulations, both for

accuracy and linearity. The two PMP-CPCs feature only minor differences with the GRIMM model showing a better accuracy and the TSI PMP-CPC a slightly better linearity.

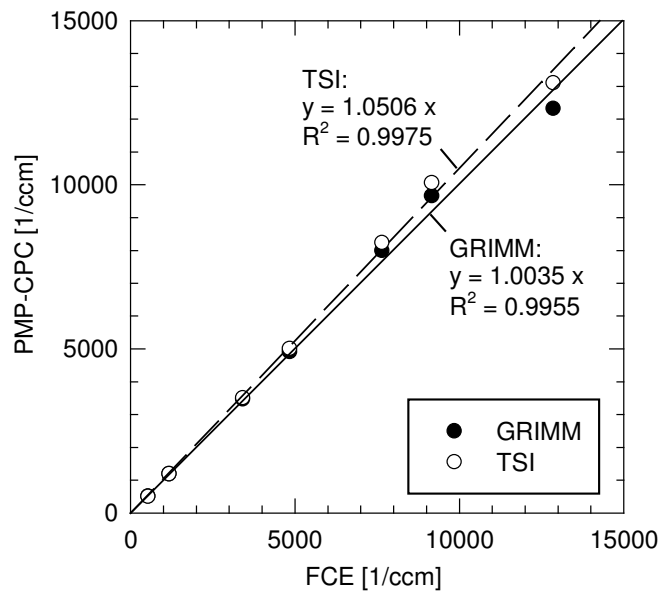

Fig. 2. Accuracy and linearity of the two tested CPCs.

Efficiency of the CPCs was alternately measured for 23 nm and 41 nm particles, each for two minutes, and the measurement was repeated 14 times to explore the reproducibility. The measured efficiencies, compiled in Tab. 1, refer to the ratio of number concentration measured by CPC and number concentration measured by FCE and constitute mean values and standard deviation from the 14 measurements.

Table 1: Efficiency of the tested CPCs. Values are in %.

	TSI PMP-CPC	GRIMM PMP-CPC	Reference CPC
23 nm	55.50 ± 0.09	59.84 ± 0.14	99.43 ± 0.11
41 nm	86.38 ± 0.44	93.59 ± 0.52	101.42 ± 0.61

The efficiency of the reference CPC, being essentially 100%, proves that the contribution of multiple charged particles was negligible during these measurements. Thus the combination of (1) a MiniCAST soot generator, adjusted to produce sufficiently low mean particle size and (2) a GRIMM DMA with a ²⁴¹Am Neutralizer constitutes a source of monodisperse particles suitable for the calibration of PMP-CPCs. The efficiencies of the two PMP-CPCs are within the range specified by the PMP regulations with the exception that the efficiency of the TSI the TSI PMP-CPC was slightly below the required limit of 90% for 41 nm particles.

The PMP regulations do unfortunately not specify all details for the tests of a PMP-CPC and hence slightly different results from different experimental setups must be expected. This comparison showed however that two commercial PMP-CPCs feature a quite similar properties despite the different test procedures used by the manufacturers.